

Serie MM10 - Potentiometric Linear Transducer

- Conductive plastic element, resolution quasi infinite
- Electrical travel from 8 mm to 15 mm
- Small dimensions
- Double sleeve bearing
- High Lifetime
- Spring return optional

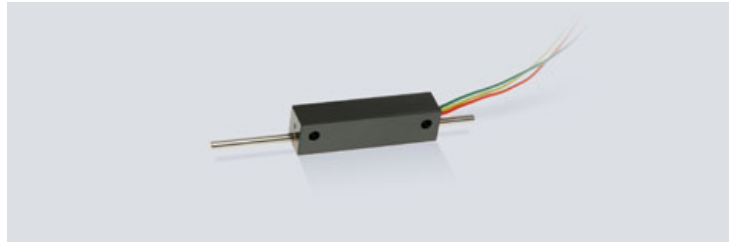

The compact series MM are mounted in a Dusoplast housing. The stainless shaft can be provided with a spring return device, thus it is useabel as a sensor.

Drawing

MM10_8 / MM10_11 / MM10_12
with or without spring

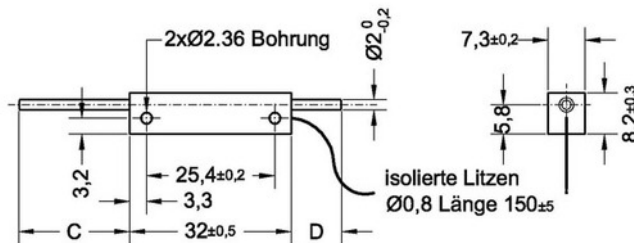

MM10_15
without spring

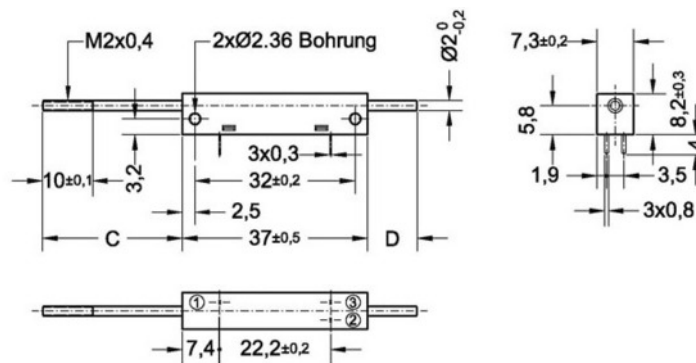

MM10_15
with spring

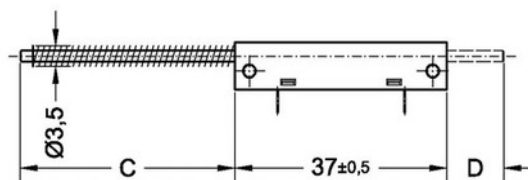

Serie MM10 - Potentiometric Linear Transducer

Dimensions

Type	MM(R)10_8	MM(R)10_11	MM(R)10_12	MM10_15	MMR10_15
C max. [± 1 mm]	20	22	23	28	37
C min. [± 1 mm]	10	10	10	10	19
D max. [± 1 mm]	20	22	23	28	18
D min. [± 1 mm]	10	10	10	10	0

Wiring:

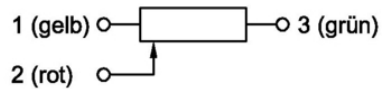

Diagram is equivalent to the shaft position in the drawing above

Electrical Data	MM10_8	MM10_11	MM10_12	MM10_15
Electrical Travel [$\pm 0,5$ mm]	8	11	12,7	15
Resistance Values	1, 2, 5, 10, 20 kOhm			
Resistance Tolerance	$\pm 15\%$ ($\pm 10\%$ optional)			
Linearity Tolerance	$\pm 2\%$ ($\pm 1\%$ optional)			
Linearity Tolerance, best possible	--	$\pm 0,5\%$	--	--
Resolution	<0,01 mm			
Power Rating at 40°C	0,2 W			0,3 W
Temperature Coefficient Resistor	400 ppm/K			
Starting Resistance	<2%			
Insulation	> 1000 MOhm (bei 500 VDC)			
Dielectric Strength	500 Veff. / 1 min.			
Maximum Wiper Current	1 mA			
Recommende Wiper Current	< 1 μ A (voltage divider)			

Serie MM10 - Potentiometric Linear Transducer

Mechanical Data	MM10_8	MM10_11	MM10_12	MM10_15
Mechanical Travel	8 ± 1 mm	12 ± 1 mm	13 ± 1 mm	15 + 5/-0 mm
Maximum Operating Friction MM	0,3 N			0,5 N
Maximum Operating Friction MMR	3 N			5 N
Stopper strength statically	10 N			
Weight	≈5 g			
Rod Bearing	2 Sleeve Bearings			
Max. Displacement Speed	2 m/s			
Average lifetime (shaft movements)	MM: 40 Mio. MMR: 20 Mio.			
Housing Material	Duroplast			
Rod Material	stainless Steel			
Terminal Material	MM 10_8, 11, 12: 3 insulated wires Ø0,8mm, length 150mm ± 5mm MM 10_15: gold-plated solder lugs (opt. 3 wires AWG28)			

Ambient Conditions	
Operating Temperature	-25 ... + 105° C
Storage Temperature	-40 ... + 125° C
Vibration	15 g / 10...2000 Hz
Shock	50g / 11ms
Protection Class	IP40 / optional IP54 with different connection

Options	
Mechanical	Electrical
<ul style="list-style-type: none"> • Special shaft (length, shape, thread) • Spring return device (lower lifetime) • IP54 (Attention: different mechanical dimensions) 	<ul style="list-style-type: none"> • Special resistance value • Tighter tolerances • MM 10 15: connection with wires instead of solder lugs

Order Code						
Series	Spring	Type	Elec. Travel	Resistance Value	Res. Tolerance	Lin. Tolerance
MM	- R (with spring)	10	8 11 12 15	R1K R2K R5K R10K R20K	W ± 15% W ± 10% opt.	L ± 2% L ± 1% opt.
Example: MM R 10 12 R2K W15% L2% (Type MM10 with spring return device, electrical travel 12.7 mm, resistance value 2kOhm, resistance tolerance ± 15%, linearity tolerance ± 2%)						

The specifications and information in this datasheet cannot consider all special demands that are caused by the application. Because of this, they are no general description of the properties of the product.

21. April 2010. All specifications are subject to change without notice.